



Allie Baby Crib

Model No.: I4588
Po #:
Serial #:



WARNING:

READ ALL WARNING & SAFETY INSTRUCTIONS BEFORE ASSEMBLING CRIB. KEEP INSTRUCTIONS WITH CRIB FOR FUTURE USE.





First remove hardware from box and sort by size. Check to see that all hardware and wooden pieces are present before assembling. Follow instructions listed below in the proper sequence as numbered to assure fast, easy and correct assembly.

WARNING!

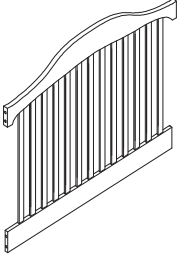

1. DO NOT attempt to repair or modify parts with cracks or defects. Please contact us for immediate replacement.
2. This product is for home use and is not intended for use in schools, day care centers or other commercial establishments.
3. Must be assembled by a capable adult.

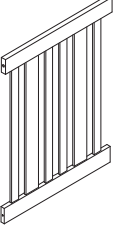
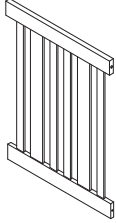
◆ PARTS IDENTIFICATION

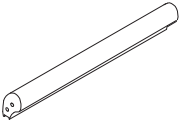
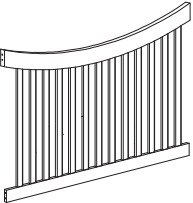
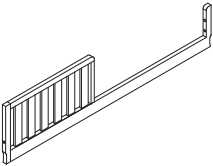
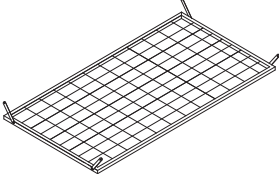
(Do not assemble crib if parts are defective. Please contact AFG for exchange or keep the original box for return authorization.)

<p>A. Headboard (1 pc)</p> 	<p>B. Rear Left Leg (1 pc)</p> 	<p>C. Rear Right Leg (1 pc)</p> 	<p>D. Left Side Panel (1 pc)</p> 
<p>E. Right Side Panel (1 pc)</p> 	<p>F. Front Left Leg (1 pc)</p> 	<p>G. Front Right Leg (1 pc)</p> 	<p>H. Top Rail (2 pcs)</p> 
<p>I. Front Panel (1 pc)</p> 	<p>J. Guard Rail (1 pc)</p> 	<p>K. Mattress Support (1 pc)</p> 	

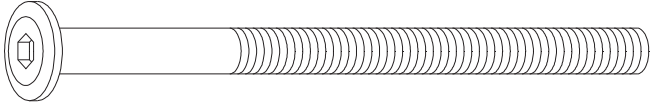
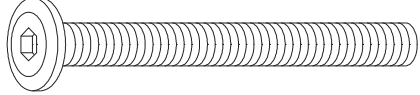
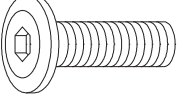
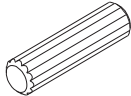
◆ HARDWARE

<p>1. Bolt 1/4" x 3" (8 pcs)</p> 		<p>2. Bolt 1/4" x 1-3/4" (16 pcs)</p> 	
<p>3. Bolt 1/4" x 3/4" (4 pcs)</p> 	<p>4. Wood Dowel 5/16" x 1-3/16" (12 pcs)</p> 	<p>5. Barrel Nut (8 pcs)</p> 	<p>6. Wrench (1 pc)</p> 

CRIB ASSEMBLY

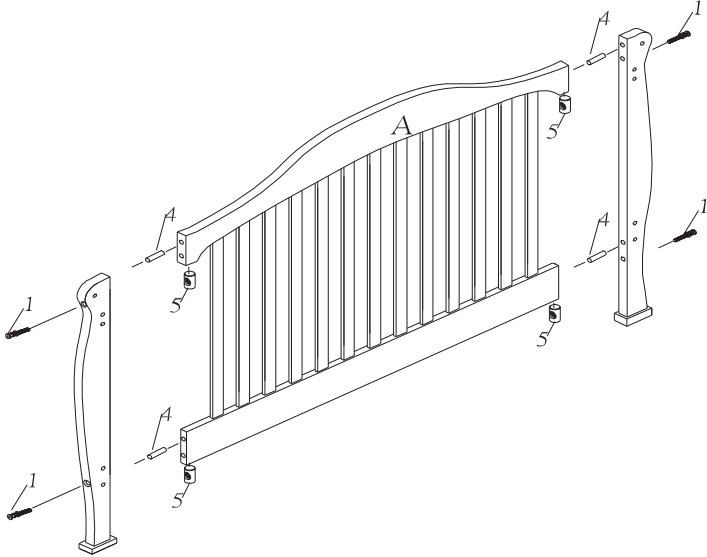
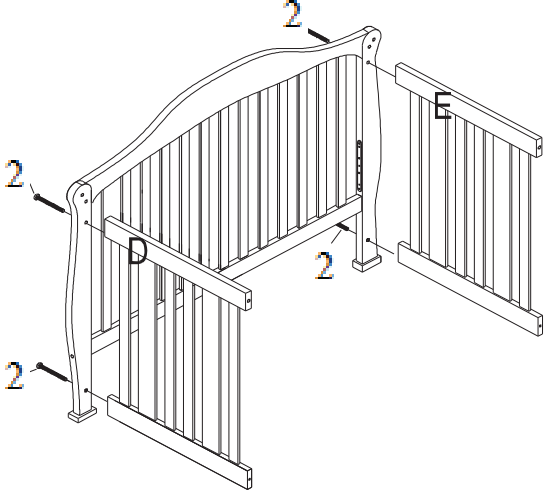
	<p>STEP 1:</p> <ol style="list-style-type: none"> Place 2 dowels (#4) into top and bottom holes of Headboard (A). Attach Rear Left Leg (B) by using 2 barrel nuts (#5) on the underside of each corner of the headboard before inserting 2 bolts (#1) into top and bottom holes. Tighten firmly with wrench (#6). Place 2 dowels (#4) into top and bottom holes of Headboard (A). Attach Rear Right Leg (C) by using 2 barrel nuts (#5) on the underside of each corner of the headboard before inserting 2 bolts (#1) into top and bottom holes. Tighten firmly with wrench (#6).
	<p>STEP 2:</p> <ol style="list-style-type: none"> Insert 2 bolts (#2) from the Rear Left Leg (B) into the Left Side Panel (D). Insert 2 bolts (#2) from the Rear Right Leg (C) into the Right Side Panel (E). Do not tighten all bolts yet. This will make the attachment of the Top Rails (H) to the side panels easier.